

# Leica RTC360: A new approach to Terrestrial Laser Scanning White Paper



[leica-geosystems.com](http://leica-geosystems.com)



- when it has to be **right**

**Leica**  
Geosystems

# Leica RTC360: A new approach to the Terrestrial Laser Scanning workflow

Andrea Biasion (Switzerland), Thomas Moerwald (Switzerland),  
Bernd Walser (Switzerland) and Gregory Walsh (USA)

## 1. Summary

This paper presents and summarises the innovations introduced to the Terrestrial Laser Scanning workflow by the RTC360 3D Reality Capture solution.

With the RTC360 solution, Leica Geosystems creates a powerful and efficient workflow for Terrestrial Laser Scanning. It has been designed as an overall system: from data acquisition in the field, to the final deliverable in the office. The system is built around three main elements: the RTC360 3D laser scanner, Cyclone FIELD 360 mobile-device app and Cyclone REGISTER 360.

The RTC360 solution (RTC stands for Reality Capture) has the primary goal to be suited to non-surveying professionals, due to the high level of automation and data enhancement on the field. As 3D scanners over the last years have become much faster, more accurate and more efficient, one of the main obstacles for the wider adoption of the terrestrial laser scanner as reality capture technology, is the complexity of the registration of the scan data coming from different positions.

The RTC360 solution addresses this problem by automating the registration process and making results directly verifiable in the field. The key embodied technology is the "Simultaneous Location and Mapping" (SLAM) method, integrated into the Visual Inertial System (VIS) of the RTC360 laser scanner. By continuously tracking the pose of the RTC360 while moving, VIS allows to align the point-clouds in real-time on the field.

Cyclone FIELD 360 mobile-device tablet app provides field functions such as data check, review and data enhancement.

Cyclone REGISTER 360 completes the workflow with fully automated data registration and deliverables creation.

## 2. Introduction

Terrestrial Laser Scanning is an established technology, adopted in multiple application fields.

Traditionally the productivity, intended as time needed to capture and document a project site, is limited by technological factors. During the laser scanner data

collection phase in the field, operators are not actively involved. Also, the office data processing still requires alternance of human and machine work time, making the traditional workflow time consuming.

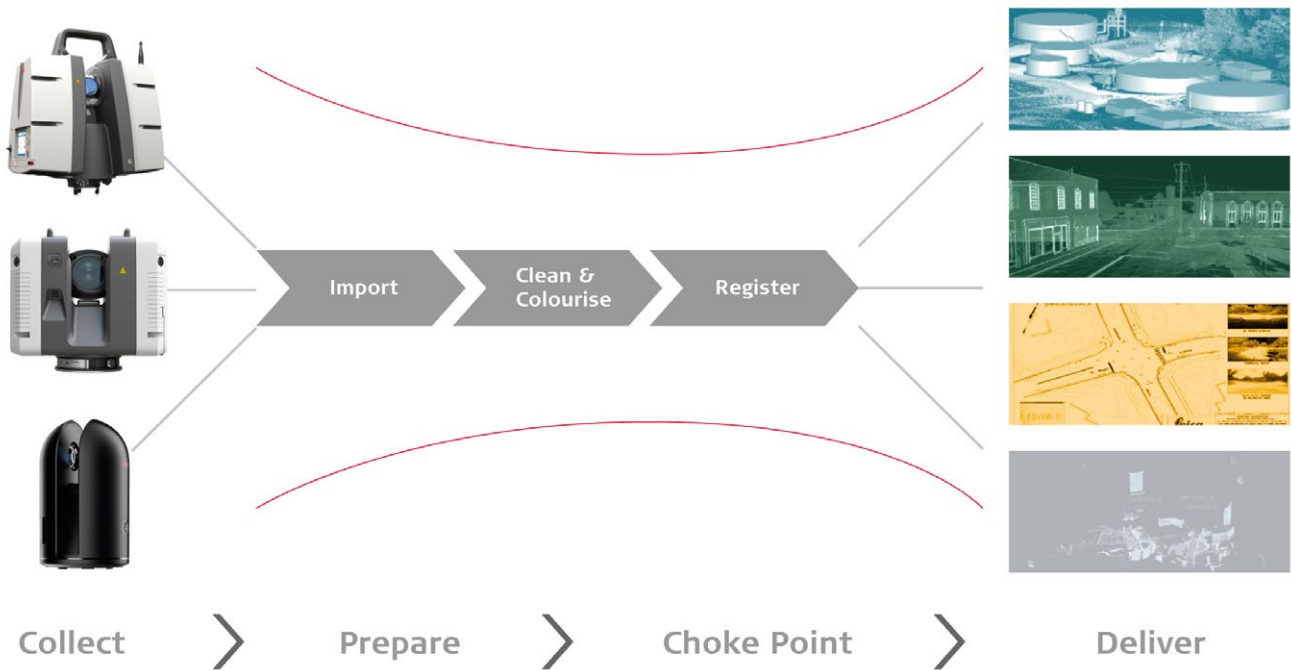

**Figure 1:** The RTC60 workflow, from field data capture to final deliverables.

The RTC360 workflow is designed to improve both the field and the office productivity, with the overall result of collecting and processing 12 scan setups per hour.

During movement, 5 cameras and an Inertial Measurement Unit (IMU) are activated for Visual-Inertial Localisation, i.e. to compute the 6 degrees of freedom of the pose transformation from the previous and next scan station. With this so-called delta pose, the point clouds of the two scans can be aligned.

In case of moving objects on the project site, the RTC360 can collect a double scan, that takes additional collection time in the field but allows the point cloud to be automatically cleaned during the office processing of the data.

When the scanner is collecting setup data (scan, images), the field operator can enrich the already collected data using Cyclone FIELD 360 mobile-device app.

The full field workflow is simplified by the physical size of the RTC360, and by the complete integration with the lightweight tripod. Due to the tilt estimation, no levelling is needed. Therefore, the device is ready to be carried around coupled with the tripod.

The remainder of this paper proceeds as follows: Section 3 describes the HDR data collection, Section 4 explains how VIS technology works and is used to pre-align point-clouds. In Section 5 and 6, we demonstrate the usage of our REGISTER 360 software in the field and in the office respectively. Section 7 summarises the paper.



### 3. HDR data collection

The RTC360 laser scanner is able to collect High-Dynamic Range (HDR) 3D and image data. The dynamic of a sensor can be defined as the ability of the sensor to be sensible to different level of inputs. HDR is popular in photography, where the same picture is collected with different exposure settings to obtain the best exposure value for each pixel. The RTC360 extends these logics to the 3D data and to the attitude sensors.

HDR is not only about data dynamics. Having HDR settings by default makes some traditional user settings

unnecessary, improving simplicity and accessibility for unexperienced professionals and early adopters. The key to achieve such a result is to combine HDR with speed. The increased dynamic shall not impact the efficiency.

For in field operations, one important factor is the physical size and weight of the system. The RTC360 laser scanner, coupled with the dedicated lightweight tripod, represent a system that can be carried around any project site with minimal effort, transported from setup to setup by a single user, for an entire working day.

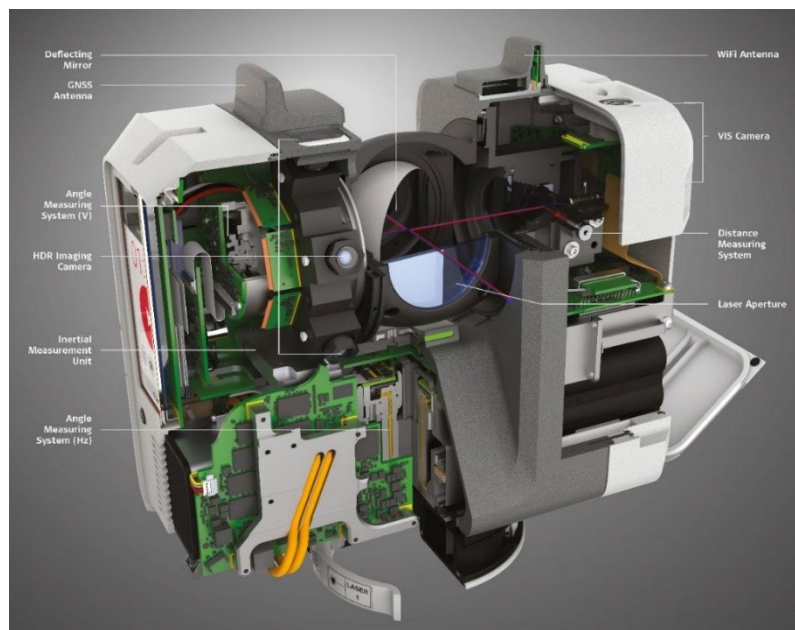

Figure 2: A look inside the RTC360

#### 3.1 HDR image collection

The RTC360 collects images of the full Field of View (FoV) using three 12 Megapixel (MP) cameras placed on the frame, recording 5 HDR brackets in 12 horizontal positions.

The three HDR imaging cameras are disposed on a radial array, embodied in the scanner frame. Each camera is composed by a 12 MP colour sensor vertically oriented, and a 62° vertical FoV lens. The three cameras cover the full vertical FoV, considering the bottom nadir hole and the required overlap. The horizontal FoV is 48°, such that the vertical overlap given by the 12 positions (30° shift) is guaranteed over the full horizon. The resulting

high level of overlap between multi-images improves the results of the blending algorithms.

Each HDR bracket differs from the previous by one stop, and the combination of exposure values and ISOs are predefined, no matter what the illumination conditions of the scene are. No light measurement procedures are needed before the actual image collection because no estimation is needed. Timewise, this can be translated into a fixed 1-minute HDR images collection time.

Merging the HDR images results in a total raw image resolution of 423 MP (12 MP x 3 cameras x 12 positions).

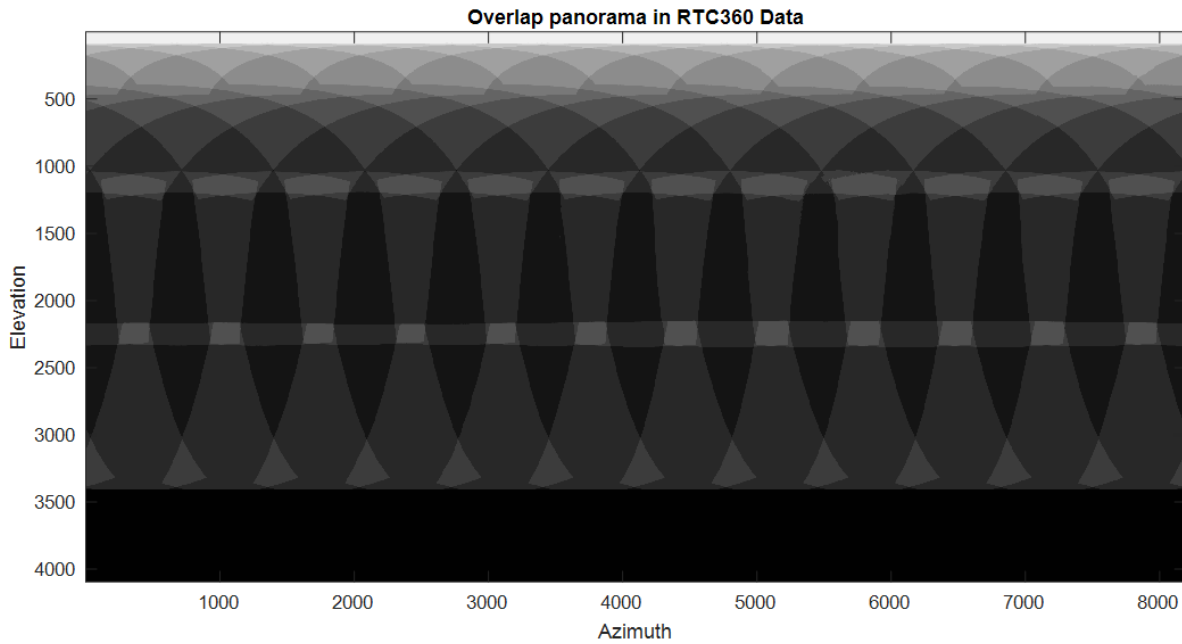

**Figure 3:** RTC360 HDR images overlap in the panoramic image.

## 3.2 HDR 3D data engine

The overall 3D points quality of laser scanners has increased over the last few years. One of the main challenges for distance measurement functionalities is the ability to measure reliable points on different kinds of surfaces. It is known that several factors have an impact on the success of the measurements: distance of the surface, reflectivity, angle of incidence, etc.

In particular the albedo of the surface, defined as the ratio of the emitted laser light that is reflected, might

significantly impact the completeness of the collected point cloud. To overcome this physical limitation, an HDR-like approach on the Electronic Distance Measurement (EDM) system is needed.

The way the HDR EDM is implemented on the RTC360 is through a modulation of the emitted laser beam in two pulses, called strong and weak.

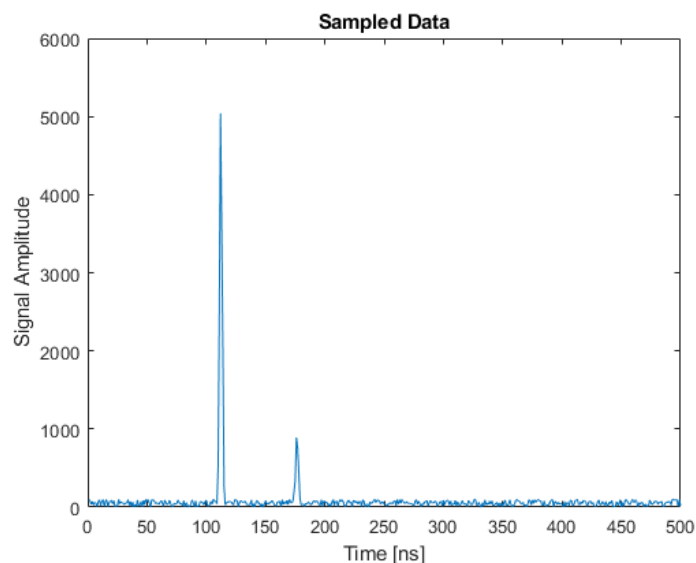

**Figure 4:** Emitted EDM pulses on RTC360.

The two pulses are shifted by 75ns, creating almost no visual artefacts in the point cloud grid. The resultant point is the combination of the received components of the two pulses.

The strong pulse carries more energy than the weak one, resulting more sensitive on low reflectivity surfaces. Points measured on low reflectivity surfaces are mainly composed by the strong pulse reflection. On

high reflectivity surfaces the strong pulse return would saturate the receiving diode, therefore the weak reflected pulse is predominant in the point distance determination.

The energy ratio between weak and strong pulses is some 1:7 and helps the RTC360 EDM to extend its dynamic towards low reflectivity surfaces, compared to previous versions of the EDM modules.

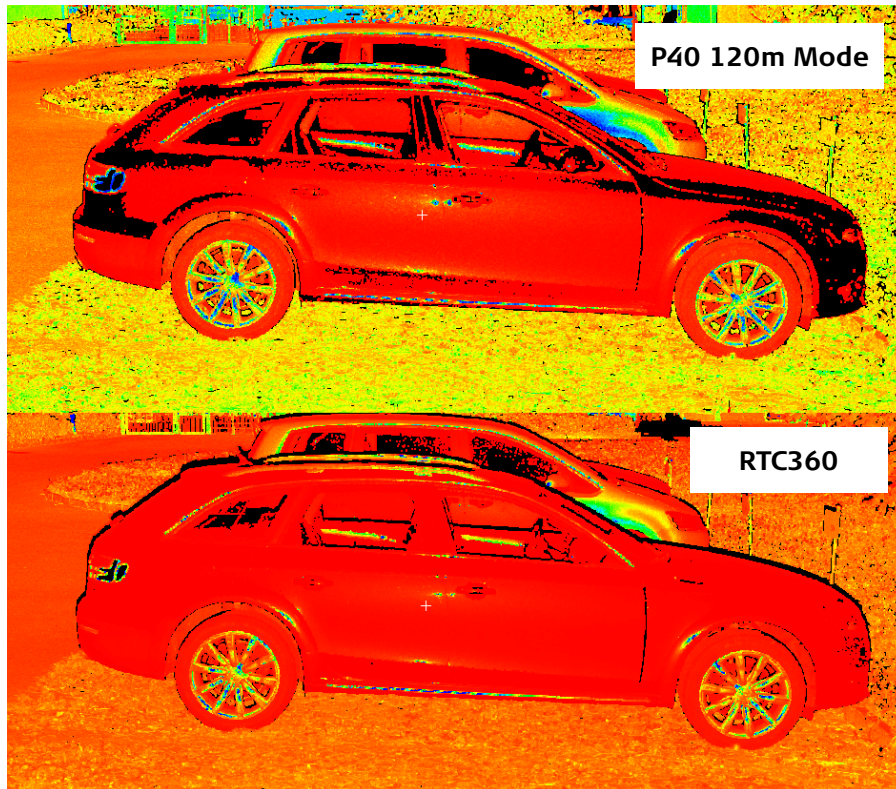

**Figure 5:** Comparison of the same scan of a black car performed with ScanStation P40 and RTC360..

Additionally, the data measured on low reflective surface is not only more complete, but also results in a lower noise range, since the pulse energy is higher.

Every two emitted pulses, one point is measured. As the RTC360 measures up to 2 million points per second, up to 4 million pulses per second are emitted by the EDM module of the RTC360.

## 4. VIS: The Visual Inertial System

The purpose of the Visual Inertial System (VIS) is to determine the relative position and orientation between two consecutive scanner setups. The 6 degrees of freedom are computed automatically, without the need of any user interaction. Based on the relative positioning, the second point cloud can be transformed in the coordinate system of the first. This initial pre-alignment is highly valuable for a preliminary user check and an automatic adjustment with ICP (Iterative Closest Point) algorithms.

The delta-poses of consecutive scan stations are stored as metadata for every job. Hence, it is applied to the data in the field via Cyclone FIELD 360 and to the office processed data.

The working principle of VIS is the Visual SLAM (Simultaneous Location And Mapping). It combines visual information from five cameras with inertial measurements from an IMU, yielding a highly robust and accurate pose estimation system.

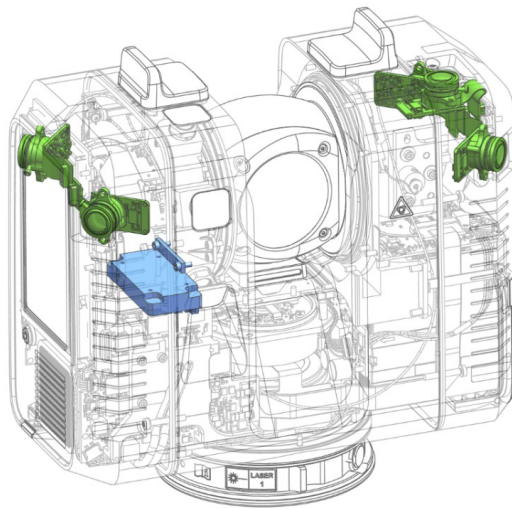
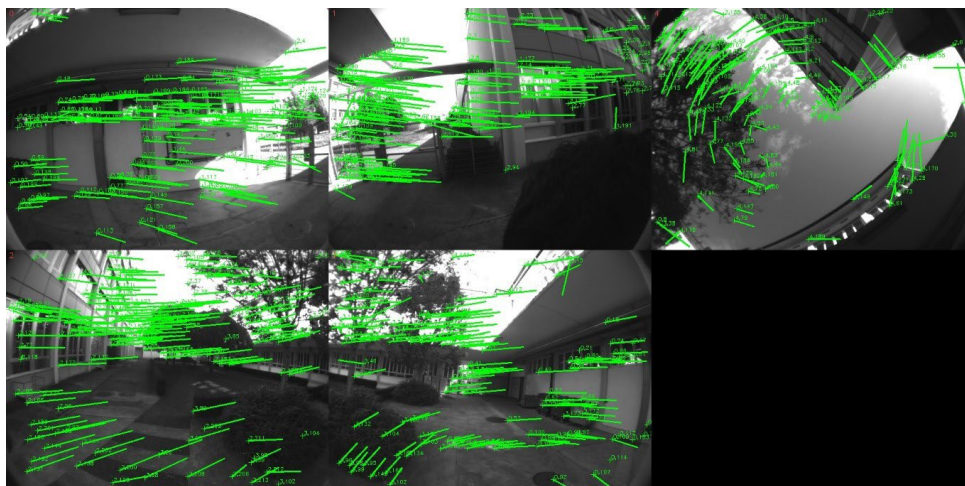

**Figure 6:** Hardware components of the Visual Inertial System.

The five, 2 MP global shutter cameras are located close to the four top corners of the scanner, plus one pointing upward. This configuration guarantees the best coverage of the full horizon, plus the additional support of the fifth camera.

Once the scan has been collected at the first setup, the VIS algorithm identifies visual features on the first set of

images streamed from the five cameras. These points, thanks to the relative calibration of the 3D engine and the VIS cameras, are available as 3D points. The back intersection of this first set of 3D points in the VIS streaming gives the computed position of the scanner as starting point of the VIS tracking.

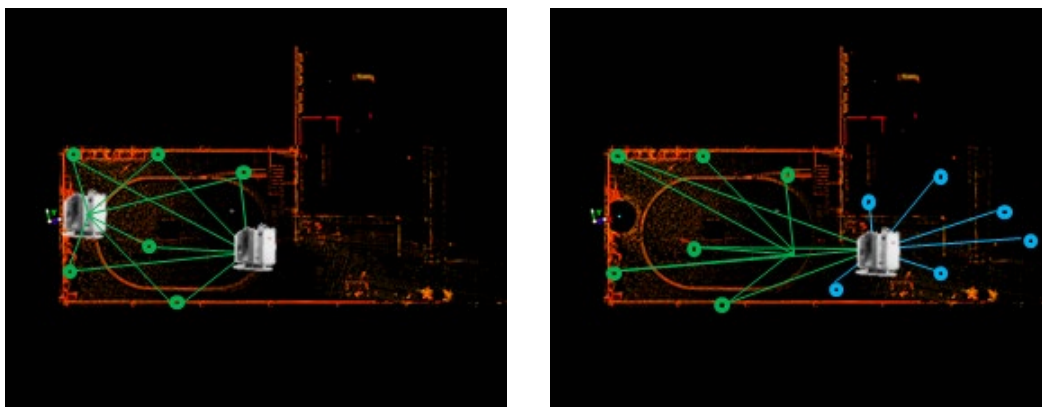

**Figure 7:** Features extraction and tracking in the VIS images.



When the scanner is moving, the continuous process of features, observation and tracking via resection allows

the VIS to compute in real time the scanner pose in the coordinate system of the first setup.



**Figure 8a and 8b:** Features extraction and tracking in the VIS images.

When the scanner is moved outside of the original scene, where the features are available as 3D scan points, VIS needs to generate new 3D features in order to propagate the position through “unknown” environment.

The IMU measures accelerations and angular rotations. These measurements are fused with the poses resulting

from the image tracking in a Kalman filter. At the end of the movement, all intermediate poses (and the final one) are recomputed by means of a bundle adjustment. This yields a more accurate result, that takes into account all the observations along the track.

## 5. Cyclone FIELD 360

Cyclone FIELD 360 is the mobile-device app, running on Android or iOS tablets, and is designed to support users to: review the data, check the pre-registration of setups and enrich the data in the field.

The tablet device connects to the RTC360 via Wi-Fi, and retrieves for each setup a reduced version of the collected data. In order to improve productivity, that

transfer phase shouldn't take longer than a couple of seconds. This is achieved by creating a lightweight preview version of the data right after the end of the collection. The size of this transferred object is significantly smaller than the full data, but still preserves geometries and image content.

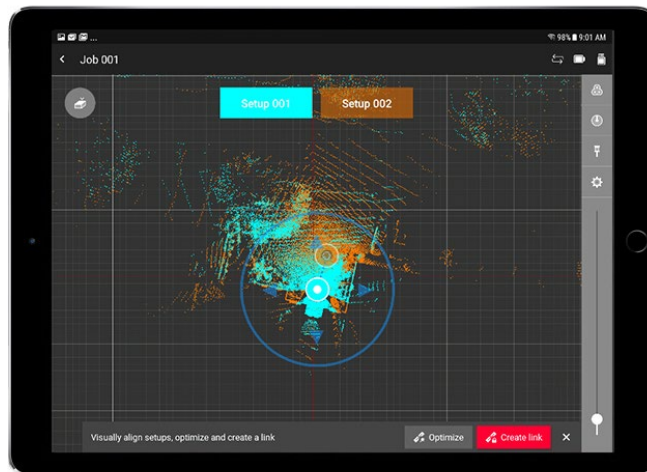

**Figure 9:** Data transmission and synchronisation between the three components of the RTC360 solution.



Unlike other scanning systems, the field registration workflow of the RTC360 solution allows the user to get to a registration directly in the field, in a very short period of time. When there is no approximate delta pose available between two consecutive setups, the

task of registering them might be trivial, especially for inexperienced professionals. The procedures for providing to the registration software an accurate enough position for the ICP algorithms are simplified when the VIS delta pose is available.



**Figure 10:** Visual alignment in Cyclone FIELD 360.

Additionally, users can benefit from the availability of the data on Cyclone FIELD 360 for verification and to enrich the data with additional information collected in the field. These are attached to the project, geographically

located, and could be several types of tags: pictures, videos, audio notes, text note. Generally, any file could be attached.

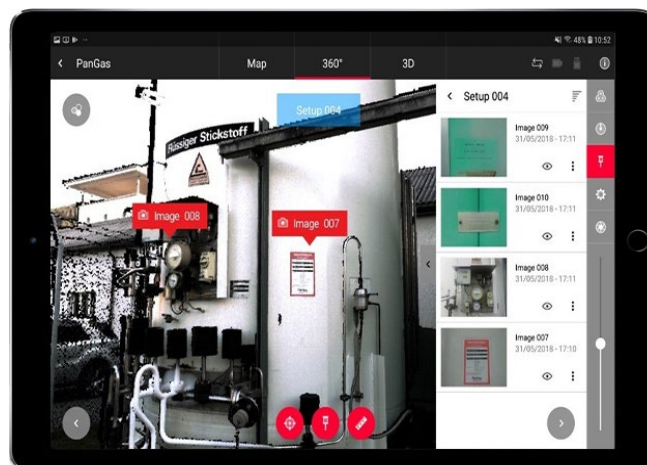

**Figure 11:** Data tagging in Cyclone FIELD 360.

All the changes that the user applies on the original data (alignment, tags, measurements) are synchronised between Cyclone FIELD 360 and the RTC360. There is a

double direction communication channel between the two components. The hub where the data integrity is preserved is the scanner and the USB memory device.

## 6. Cyclone REGISTER 360

At the end of the field operations, the collected data is transferred from the RTC360 to an office PC via the USB memory device. With a simple drag and drop, the user

can quickly visualise the preview of the data collected, with a look and feel very close to Cyclone FIELD 360 app.

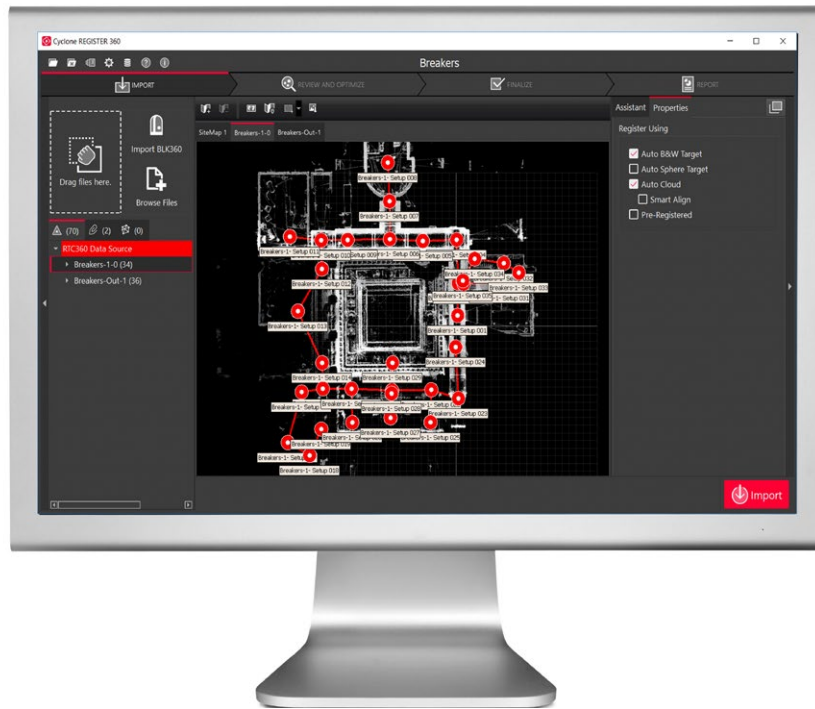

Figure 12: Data preview in the import area of Cyclone REGISTER 360.

During this phase, the operator can review the alignments created in the field and make some last-minute changes. Then, the press of the import button executes the actual full data import. Several options are available to guide the software through the automatic registration of the data, as target extraction and automatic cloud-to-cloud registration.

During the import several steps of data processing are running. Filters are applied, as mixed pixels and oversaturated points filter. The images are processed, with the creation of the panoramic images and the colourisation of the point cloud. Finally, if any double scan data has been collected, moving objects are removed from the scene.

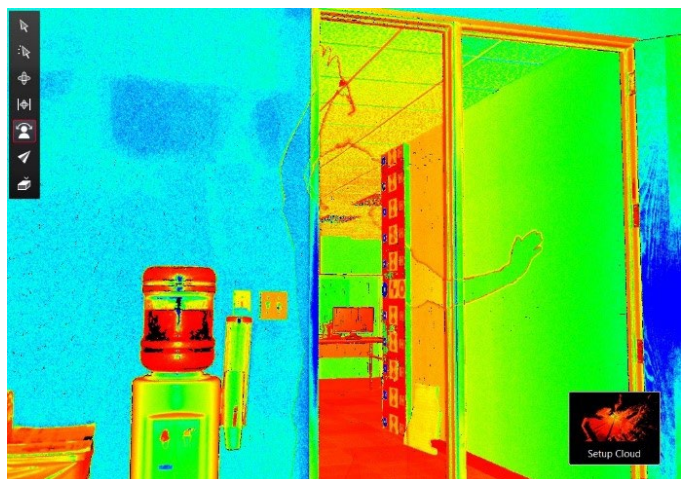

Figure 13a and 13b: Effect of the moving object filter in Cyclone REGISTER 360.

## Summary

Although 3D laser scanners are becoming more powerful and easier to use, the user workflow still presents obstacles and hurdles, especially for new adopters. The Leica RTC360 3D Reality Capture solution works in the direction of optimising the registration process and bringing efficiency and productivity to the users.

The quality and completeness of the data, as well as the speed of HDR field operations in the RTC360 solution are outstanding compared to the state-of-the-art. However, HDR data is not only about completeness and quality, but also about simplicity. Users will strongly benefit from the level of automatization. The speed of the workflow is a key factor as well, high dynamic data collection shall not impact on the speed. The physical dimensions and weight of the RTC360 and its accessories allow a single operator to carry on a full day of data collection.

Each of the three components of the RTC360 contribute to a seamless solution, where the user is able to dramatically improve productivity without any compromise.

## Biographical notes

**Andrea Biasion** is a Terrestrial Laser Scanning (TLS) Product Expert in the TLS Product Management team at Leica Geosystems AG. He received his Ph.D. in Environmental Geo-Information at Turin Polytechnic, Italy.

**Thomas Moerwald** is a Computer Vision Expert at Leica Geosystems AG. He received his Ph.D. in Electrical Engineering at the Vision for Robotics group of the Automation and Control Institute at the Vienna University of Technology.

**Bernd Walser** is a Chief Engineer Terrestrial Laser Scanning (TLS) System Design in the R&D Team at Leica Geosystems AG. He has more than 15 years of experience in developing surveying instruments and holds a Ph.D in Geodesy and Photogrammetry.

**Gregory Walsh** is the Director of Research and Development TLS Software at Leica Geosystems. He has dozens of publications and patents in a variety of fields. He received his Ph.D. in Electrical Engineering and Computer Sciences from the University of California at Berkeley.

## Contacts

Andrea Biasion  
Leica Geosystems AG  
Heinrich Wild Strasse  
9435 Heerbrugg  
Switzerland  
Tel. +41 71 727 3134  
Email: [andrea.biasion@leica-geosystems.com](mailto:andrea.biasion@leica-geosystems.com)  
Website: [www.leica-geosystems.com](http://www.leica-geosystems.com)

## **Leica Geosystems – when it has to be right**

Revolutionising the world of measurement and survey for nearly 200 years, Leica Geosystems, part of Hexagon, creates complete solutions for professionals across the planet. Known for premium products and innovative solution development, professionals in a diverse mix of industries, such as aerospace and defence, safety and security, construction, and manufacturing, trust Leica Geosystems for all their geospatial needs. With precise and accurate instruments, sophisticated software, and trusted services, Leica Geosystems delivers value every day to those shaping the future of our world.

Hexagon is a global leader in digital solutions that create Autonomous Connected Ecosystems (ACE). Hexagon (Nasdaq Stockholm: HEXA B) has approximately 20,000 employees in 50 countries and net sales of approximately 3.5bn EUR.

Copyright Leica Geosystems AG, 9435 Heerbrugg, Switzerland. All rights reserved. Printed in Switzerland – 2019.  
Leica Geosystems AG is part of Hexagon AB. 890954 – 06.19